

QUICK START GUIDE

Trimble X12

3D LASER SCANNER



The Trimble® X12 is a high-end 3D laser scanner with superior speed, accuracy, range and image quality for demanding scanning projects.

SYSTEM

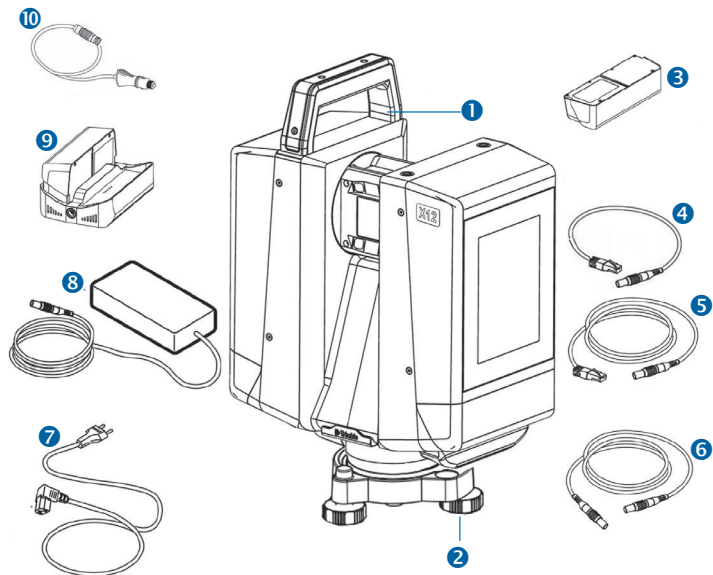

- 1 X12 3D laser scanner
- 2 Tribrach
- 3 X12 battery (x4)
- 4 Ethernet cable 0.5 m
- 5 Ethernet cable 5 m
- 6 Extension cable for power supply
- 7 Power cable with international adapters for power supply
- 8 X12 power supply for the scanner and charger
- 9 X12 battery charger
- 10 Car adapter charging cable
- 11 SD Card 128 GB*
- 12 USB with User Guide*
- 13 Quick Start Guide, Warranty Activation Card, Certificate of Calibration, Regulatory Information Document*

* = Not illustrated

FEATURES

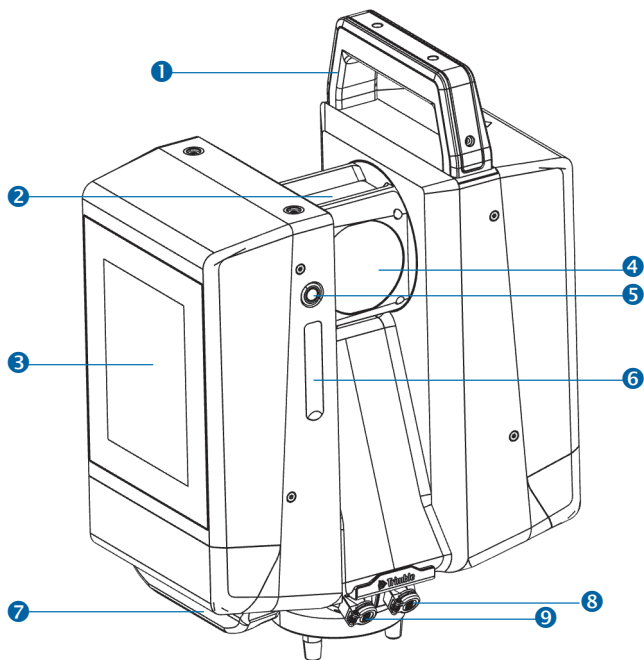

- 1 Upper handle
- 2 Integrated camera and illumination
- 3 Touch screen display
- 4 Rotating mirror for laser
- 5 ON/OFF button
- 6 SD card slot and Micro D-SUB connector
- 7 Lower handle
- 8 Power supply connector
- 9 Ethernet connector

LABELS

CAUTION – For laser safety and regulatory information, see the *Regulatory Information Document* delivered with the product.

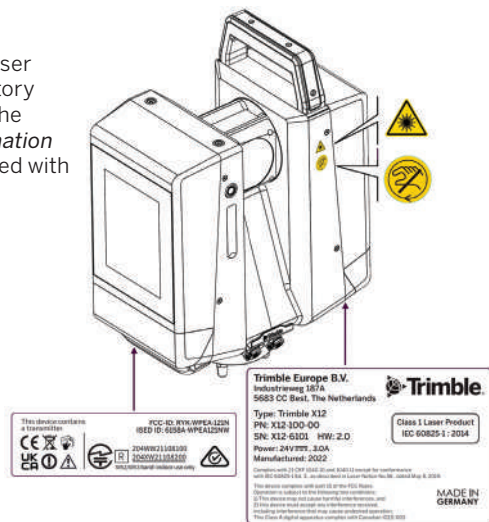

SPECIFICATIONS

Physical specification

Weight without batteries	6.7 kg (14.77 lbs)
Weight with batteries	7.7 kg (16.97 lbs)
Dimensions	150 × 258 × 328 mm (5.90 × 10.15 × 12.91 in)
Bottom of scanner to horizontal axis	232 mm (9.13 in)

Environmental specification

Ingress protection rating	IP54
Operating temperature range	-10 °C to 45 °C (14 °F to 113 °F)
Storage temperature range	-20 °C to 50 °C (-4 °F to 122 °F)

For complete technical specifications, see the *X12 Data Sheet* at geospatial.trimble.com/X12.

BATTERIES AND POWER SUPPLY

Operate with the batteries

WARNING – Before charging or using the Trimble X12 batteries, it is important that you read and understand the battery safety and environmental information. The battery safety and environmental information is available in the *X12 Regulatory Information Document*.

NOTE – Use only batteries with P/N 123810-11. The scanner is delivered with four batteries. Two are attached to the scanner and two are stored inside the transportation box.

To remove the batteries:

1. Hold the battery and press the fixing clip at the bottom.
2. Pull the battery carefully sideways out to detach it.

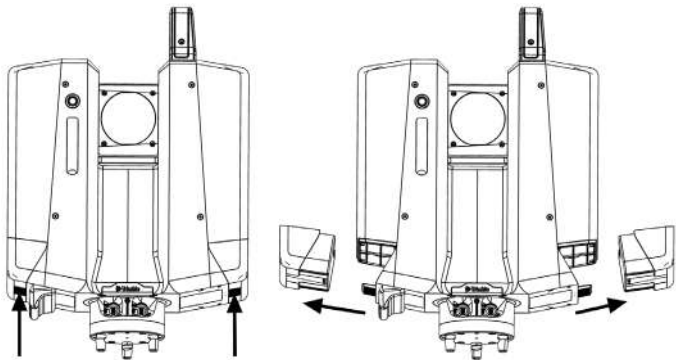

To charge the batteries:

- The batteries are delivered partially charged. Before using the batteries for the first time, charge them completely using the X12 battery charger (P/N 123810-30).

NOTE – For detailed instructions on charging the battery packs, see the *X12 User Guide*.

To attach the batteries:

- Push batteries sideways into the attachments on each side of the scanner until the clips latch.

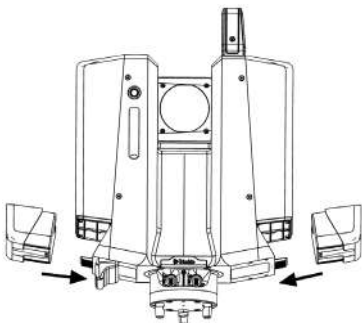

OPERATE WITH THE POWER SUPPLY

1. Connect the power supply cable to the scanner.
2. Connect the power cable to the power supply.
3. Connect the power cable to the main power supply.

CAUTION – The power supply is intended for indoor use. Use the power supply and the charger only at dry locations.

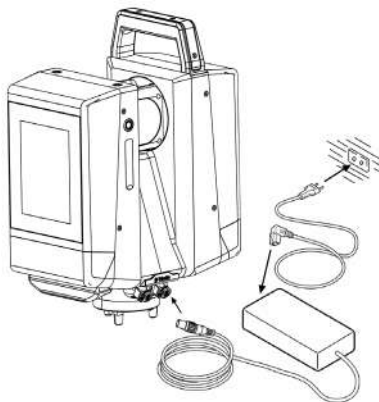

SETUP

The scanner can be set up on a Trimble Trimax survey tripod (P/N 90553-TR-SUR) or a Gitzo Series 5 scanning tripod (P/N 90572-TR). A stable setup is critical for high-precision measurements.

For detailed instructions on setting up the tripod and scanner, see the *X12 User Guide*.

INSERT AN SD CARD

CAUTIONS – The SD card and Micro D-SUB port cover on the scanner should always be attached to prevent dirt and moisture from entering into the scanner.

- Do not insert the SD card upside down or back to front. Inserting it incorrectly could damage the scanner and/or the SD card.

NOTE – Before inserting (or removing) a SD card from the scanner, ensure that the scanner is off.

1. Open the SD card and Micro D-SUB port cover.
2. Slide the SD card into the slot until it clicks into the locked position.
3. Close the SD card and Micro D-SUB port cover.

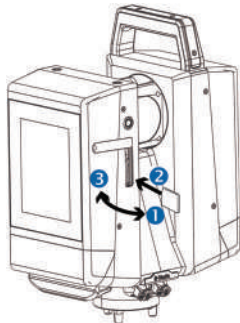

OPERATION

The scanner can be operated remotely with a controller running the Trimble Perspective field software or with its on-board user interface.

Operate with the Perspective software

Trimble recommends operating the scanner with the Perspective software for a more intuitive user experience. Automatic in-field registration and better project visibility help ensure the project is complete before leaving the field. The Perspective software also provides data redundancy with automatic transfer of data to the controller and storage on the scanners onboard SSD. If you choose to operate with the Perspective software, connect a controller to the scanner with Wi-Fi or with the provided ethernet cable.

Operate with the on-board user interface

The scanner on-board user interface is available for experienced users that prefer to use the touch screen display to operate the scanner. This workflow requires users to register scans in the office with target-based, plane-based, or cloud-to-cloud registration techniques.

For more information, see the *X12 User Guide* and the *Perspective Help*.

POWER ON/OFF THE SCANNER

Power on the scanner

Press and hold the ON/OFF button for at least 0.3 seconds. The power-up process starts and requires approximately 20 seconds to complete. During the power-up process, the deflection unit spins.

Do not touch the touch screen display during power on and the boot process.

At the first power-up, you are prompted to enter a Wi-Fi password on the on-board user interface for security. The password is required for the first Wi-Fi connection from the Perspective software.

The next time you reconnect to the scanner with the same controller the Wi-Fi connection is automatic and does not require the Wi-Fi password. If you try to connect to the scanner with a different controller, the Wi-Fi password is required again.

NOTE – The Wi-Fi password can only be reset from the scanner on-board user interface. See the *X12 User Guide*.

Power off the scanner

Press and hold the ON/OFF button for at least 0.5 seconds. The touch screen display shows **Shutdown system. Please wait..**

ADDITIONAL INFORMATION

The original document is written in English. All documents in other languages are translations from the original English document. For more information and information in other languages, go to geospatial.trimble.com/X12.

For Trimble support, go to trimble.com/support.

© 2022, Trimble Inc. All rights reserved. Trimble, and the Globe & Triangle logo are trademarks of Trimble, registered in the United States and in other countries. All other trademarks are the property of their respective owners.

Europe: Trimble Europe BV, Industrieweg 187A, 5683 CC, Best, Netherlands

North America/Rest of World: Trimble Inc., 4450 Gibson Dr, Tipp City, OH 45371, USA

P/N 123810-50, Rev B (June 2022).

