

HR150 Receiver User Guide

Introduction

Thank you for choosing the Spectra Precision® Laser Receiver HR150 from the Trimble® family of precision instruments. The HR150 is a battery-operated laser receiver that detects a rotating laser beam and indicates its position relative to the beam using LEDs.

Before using the receiver, be sure to read this user guide carefully. Included in it is information about setting up, using, and maintaining the receiver. Also included in this manual are **CAUTIONS** and **Notes**. Each of these words represents a level of danger or concern. A **CAUTION** indicates a hazard or unsafe practice that could result in minor injury or property damage. A **Note** indicates important information unrelated to safety.

Your comments and suggestions are welcome; please contact us at:

Trimble Construction Division
5475 Kellenburger Road
Dayton, Ohio 45424-1099 U.S.A.
Phone: (937) 245-5600
(800) 538-7800
FAX: (937) 233-9004
Internet: www.trimble.com

Receiver

Features and Functions

- Power/Audio Button**—is a multi-functional button that turns on/off the receiver and audio function.
- Marking Notches (both sides)**—align with the on-grade portion of the photocell and are used to mark elevation readings. The marking notches are 50mm (2 inches) from the top of the receiver.
- LEDs (front and back)**—show the position of the receiver relative to the laser beam (high, on-grade, or low), and indicate power and low-battery status.
- Level Bubble**—is used to make sure that the receiver is level.
- Photocell**—detects the laser beam when it strikes the receiver.
- Audio Port**—is the opening the sound comes out of.



- Clamp-Tab Recess**—is the area that the general-purpose clamp's release tab fits into.
- Label**—shows the serial number and bar code.
- Magnet**—holds the receiver on a wall molding, cross-T, runner, etc.
- Battery Housing**—holds two AA alkaline or Ni-Cd batteries.
- Battery Door**—holds the batteries securely in place.
- Neck Cord Holder**—allows a neck cord to be attached to the receiver.

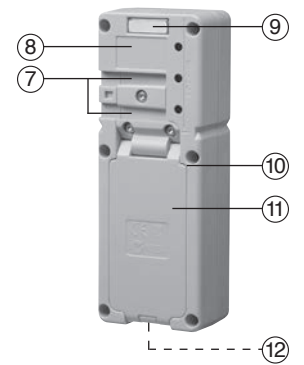

How to Use the Receiver

Installing/Removing the Batteries



- Release the battery door using your fingers, a coin, or a screwdriver. Open the door.
- Install/Remove the 2 AA batteries noting the positive (+) and negative (-) diagram on the bottom of the battery housing.
- Close the battery door and latch it shut.

Learning the Receiver Functions

Turning On/Off the Receiver

- Press the power/audio button to turn on the receiver.
Note: When the receiver is initially turned on, all LEDs and the audio signal turn on for one second (diagnostic mode).
Note: The on-grade LED flashes once every two seconds to show that the receiver is on.
- Press and hold the power/audio button for two seconds to turn off the receiver.
Note: When the receiver is being turned off, all the LEDs and the audio signal quickly turn on for one second.

Selecting the Audio Function

The receiver always starts up with the audio mode active.

- Press the power/audio button repeatedly to turn on/off the audio function.
Note: If the audio function is on, the receiver beeps quickly when the receiver is above the laser beam, slowly when below it, and continuously when centered in the laser beam or on grade.

Using the Receiver with a Laser

- Press the power/audio button to turn on the receiver.
- Position the receiver so that its photocell faces the laser.
- Move the receiver up/down until the LEDs show an on-grade reading.
Note: The top/bottom red LEDs flash when the receiver is above or below the laser beam. The green LED flashes when the receiver is on grade.

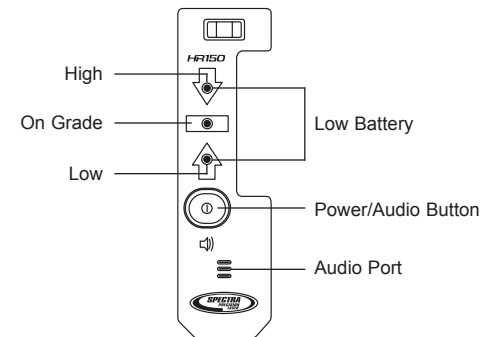

LED/Audio Information

| LED/Audio Indication | Function | Audio Output |
|---|----------------|-------------------|
| Green LED: flashes once every two seconds | Receiver is on | N/A |
| Top red LED: flashing | High | Fast beeping tone |
| Green LED: flashing | On-grade | Continuous tone |
| Bottom red LED: flashing | Low | Slow beeping tone |
| Both red LEDs: flashing in sequence | Low battery | N/A |
| Speaker beep | Audio on | 3 beeps |
| | Beam location | Single beep |

General-Purpose Clamp

The C61 general-purpose clamp allows the receiver to be attached to a survey rod or wooden pole.

Features and Functions

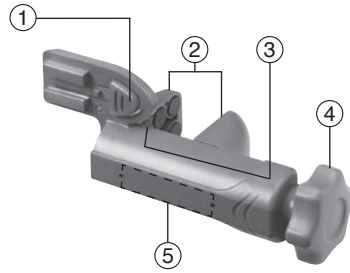

1. **Release Tab**—allows the receiver to be locked onto or released from the general-purpose clamp.
2. **Jaws**—close/open so that the general-purpose clamp can be attached to or released from a survey rod or wooden pole.
3. **Reading Edge**—aligns with the receiver's on-grade marking notches.
4. **Jaws Screw**—controls the closing/opening of the jaws.
5. **Circular Bubble Screw Holes**—are where the optional 1277-6251S grade rod circular bubble kit is mounted.

– 9 –

EMC Declaration of Conformity

This receiver has been tested and found to comply with the limits for a Class B digital device for radio noise for digital apparatus set out in the Radio Interference Regulations of the Canadian Department of Communication, and is pursuant to part 15 of the Federal Communication Commission (FCC) rules. These limits are designed to provide reasonable protection against harmful interference in a residential installation. This receiver generates radio frequency. If it's not used in accordance with the instructions, it may cause harmful interference to radio or television reception. Such interference can be determined by turning the receiver off and on. You are encouraged to try eliminating the interference by one or more of the following measures:

- Reorient or relocate the receiving antenna.
- Increase the separation between the laser and the receiver.

For more information, consult your dealer or an experience radio/television technician.

CAUTION: Changes or modifications to the receiver that are not expressly approved by Trimble could void authority to use the equipment.

– 13 –

Attaching the Receiver to the Survey Rod or Wooden Pole

1. Slide the general purpose clamp into the receiver until it “clicks” into position.
2. Turn the jaws screw counterclockwise to open the clamp's jaws.
3. Slide the survey rod or wooden pole between the clamp's jaws.
4. Turn the jaws screw clockwise to hold the general-purpose clamp securely in place.

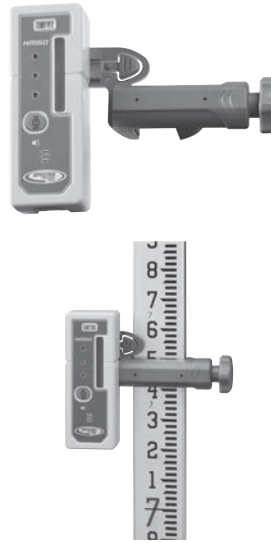

– 10 –

Declaration of Conformity

Application of Council Directive(s): 89/336/EEC
 Manufacturer's Name: Trimble Navigation Ltd.
 Manufacturer's Address: 5475 Kellenburger Road, Dayton, Ohio 45424-1099 U.S.A.
 European Representative Address: Trimble GmbH, Am Prime Parc 11, 65479 Raunheim, Germany
 Model Number: HR150
 Conformance to Directive(s): EC Directive 89/336/EEC using EN55022 and EN50082-1
 Equipment Type/Environment: ITE/residential, commercial & light industrial
 Product Standards: Product meets the limit B and methods of EN55022. Product meets the levels and methods of IEC 801-2, 8 kV air, 4 kV contact IEC 801-3, 3 V/m 26 to 1000 MHz 80%, @ 1 kHz

– 14 –

Receiver Specifications

| | |
|------------------------------|---|
| LED Channels | 3 |
| Capture Height | 50 mm (2 in.) |
| Acceptance Angle | 90° |
| On-Grade Sensitivity | Medium: 3.00 mm (1/8 in.) |
| Power Source | Two 1.5-V batteries (type LR6/AA) |
| Battery Life @ 20 °C (68 °F) | Alkaline: 70+ hours |
| Low Battery Indicator | Red LEDs flash in sequence |
| Automatic Shutoff | 30 minutes after last laser detection or push-button actuation |
| Spectral Sensitivity | Operates with red visible and infrared rotating lasers with wavelength between 610 and 900 nm |
| Marking Notch | 50 mm (2 in.) below top of receiver, on both sides |
| Operating Temperature | –20 °C to +50 °C (–4 °F to +122 °F) |
| Storage Temperature | –40 °C to +70 °C (–40 °F to +158 °F) |
| Weight | 0.3 kg (.75 lb) |
| Dimensions (H x W x D) | 13.6 x 5.0 x 2.8 cm (5.37 x 2.00 x 1.11 in.) |

– 11 –

Warranty

Trimble warrants the receiver to be free of defects in material and workmanship for a period of one year.

Trimble or its authorized service center will repair or replace, at its option, any defective part for which notice has been given during the warranty period. If required, travel and per diem expenses to and from the place where repairs are made will be charged to the customer at the prevailing rates.

Customers should send the product to Trimble Navigation Ltd. or the nearest authorized service center for warranty repairs, freight prepaid. In countries with Trimble subsidiary service centers, the repaired product will be returned to the customer, freight prepaid.

Any evidence of negligent, abnormal use, accident, or any attempt to repair the product by other than factory-authorized personnel using Trimble certified or recommended parts, automatically voids the warranty.

The foregoing states the entire liability of Trimble regarding the purchase and use of its equipment. Trimble will not be held responsible for any consequential loss or damage of any kind.

This warranty is in lieu of all other warranties, except as set forth above, including any implied warranty merchantability of fitness for a particular purpose, are hereby disclaimed. This warranty is in lieu of all other warranties, expressed or implied.

– 15 –

Notice to Our European Union Customers

For product recycling instructions and more information, please go to: www.trimble.com/environment/summary.html

Recycling in Europe

To recycle Trimble WEEE, call: +31 497 53 2430, and ask for the “WEEE associate,” or

mail a request for recycling instructions to:
 Trimble Europe BV
 c/o Menlo Worldwide Logistics
 Meerheide 45
 5521 DZ Eersel, NL



– 12 –



Trimble Construction Division
 5475 Kellenburger Road
 Dayton, Ohio 45424-1099
 U.S.A.
 +1-937-245-5600 Phone

www.trimble.com



© 2006, Trimble Navigation Limited. All rights reserved.
 Reorder PN 1277-7511 (11/06)